



# SIDEWALK PAVING DESIGN

BETTER  
MARKET  
STREET

Better Market Street will feature gray concrete pavers in an aligned pattern, with 8"x24" pavers in the main path of travel and 4"x12" pavers in the site furnishing and building frontage zones. There will be an asphalt bikeway and repurposed granite will be used as curbs and to highlight the street geometry.

## PAVING ENLARGEMENT

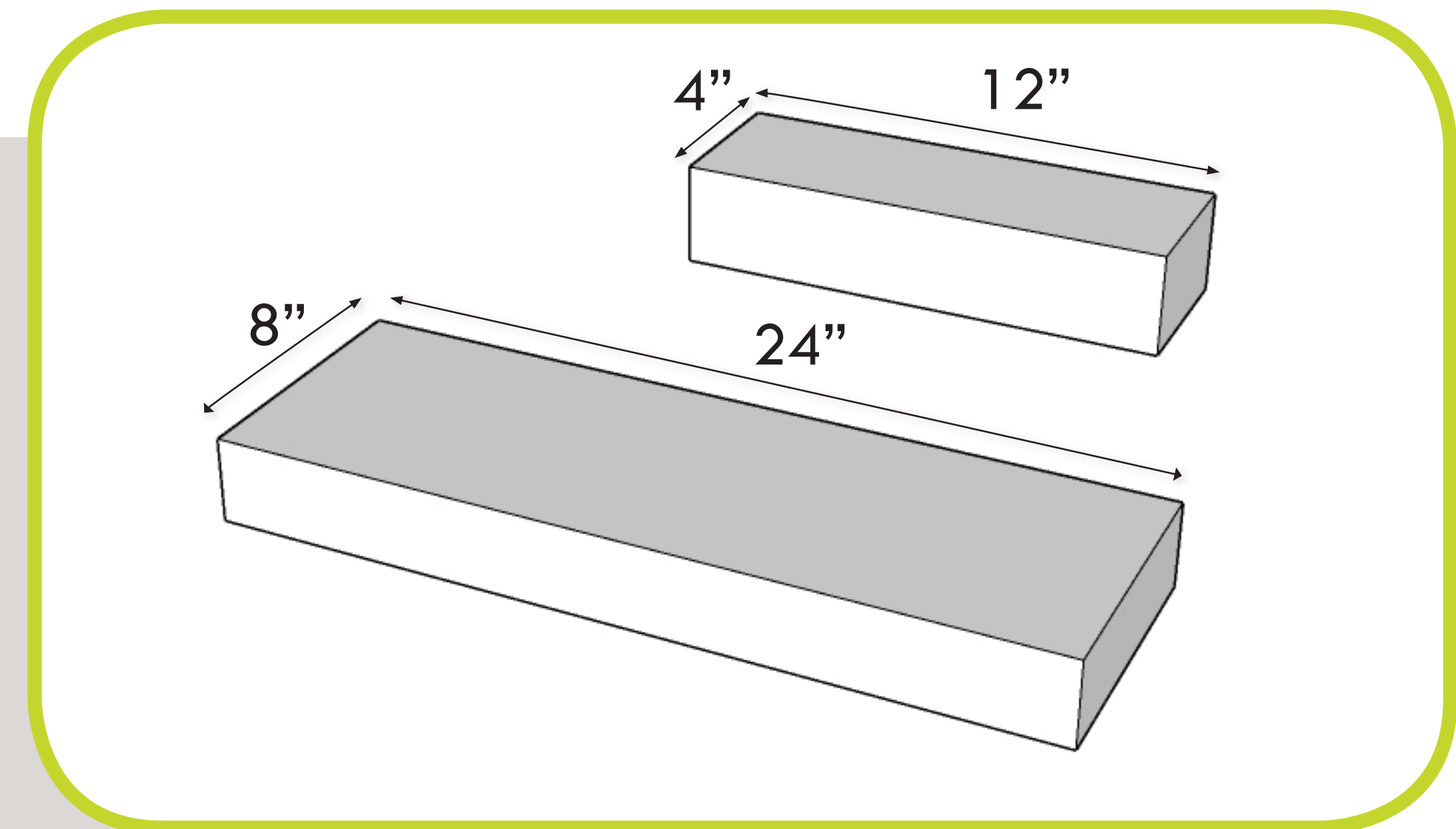
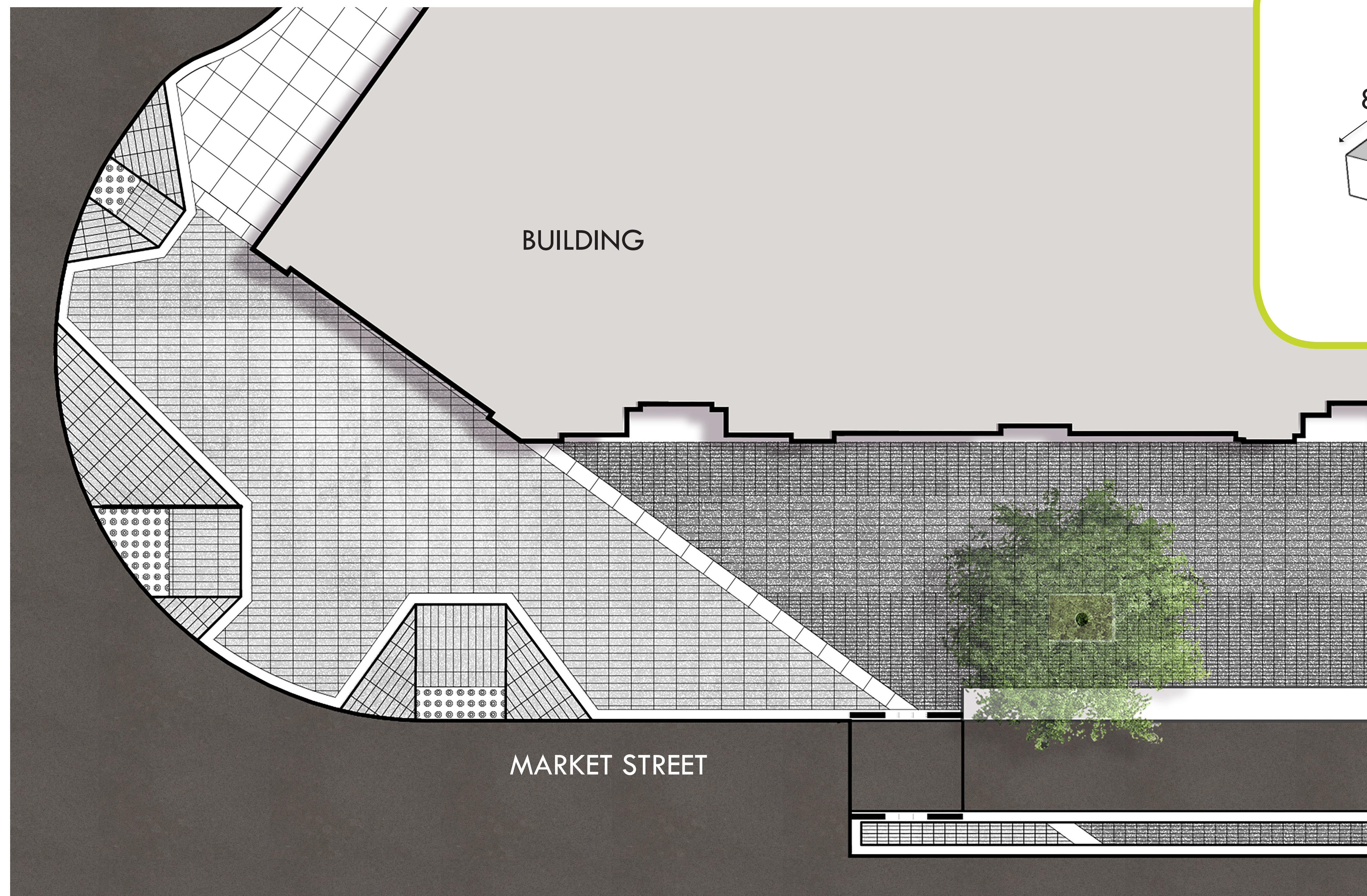

Paving Modules

5' Building Frontage Zone

9' Major Path of Travel

4'-10' Site Furnishing Zone

1'-3' Bikeway Delineator

8' Bikeway

4' Buffer

## NEXUS INTERSECTION

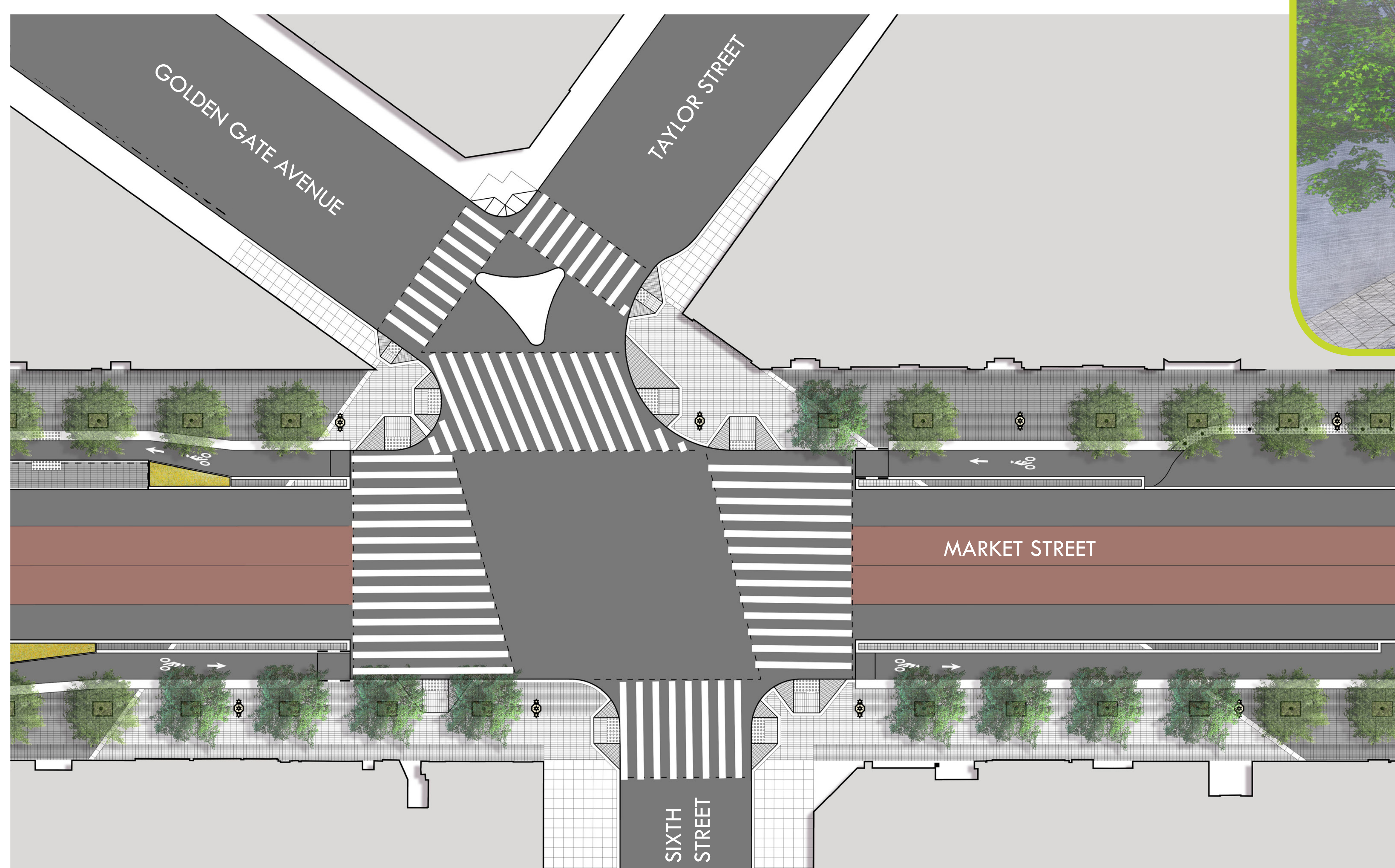

Birds-eye view of the sidewalk